

SECTION A-A

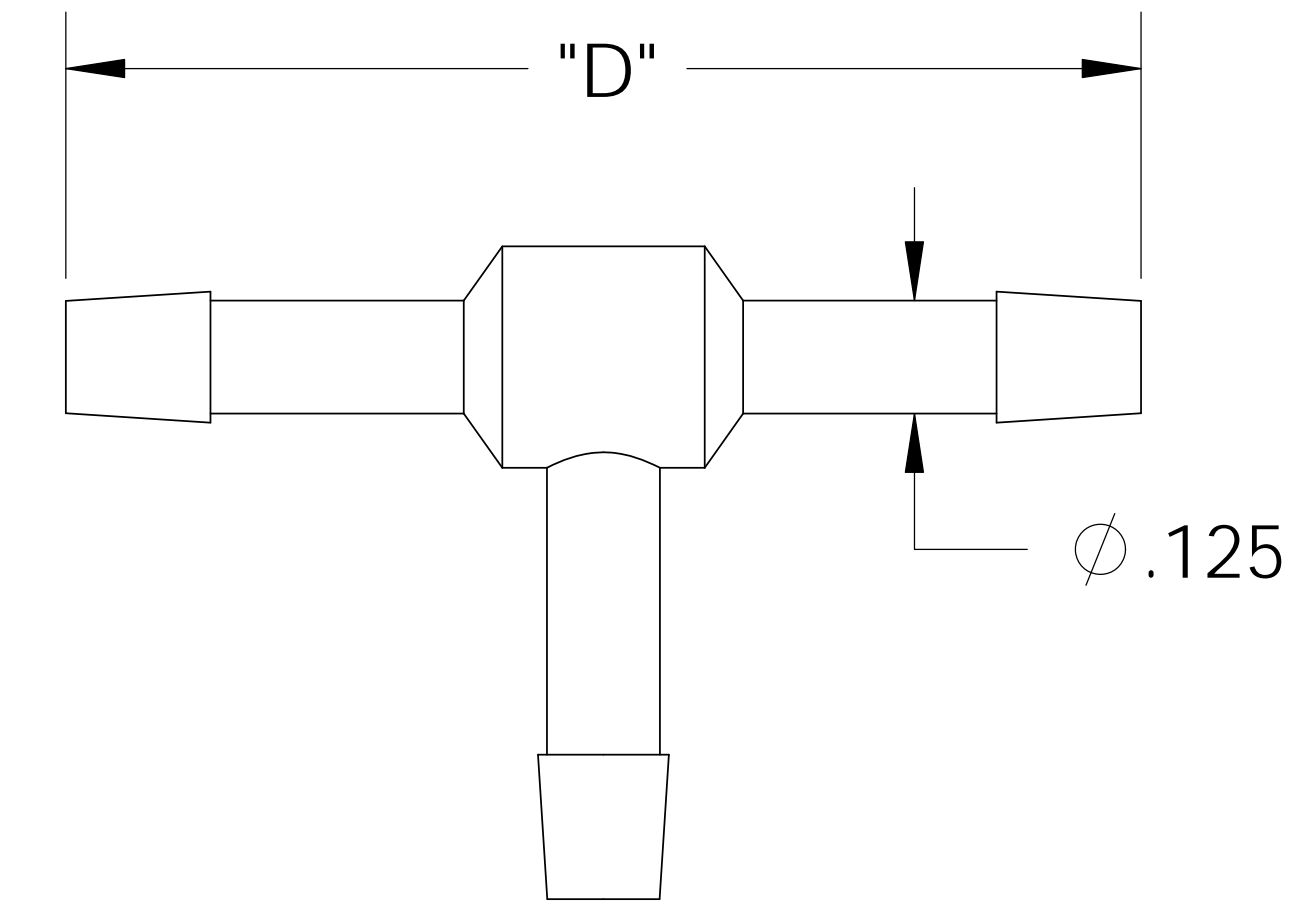
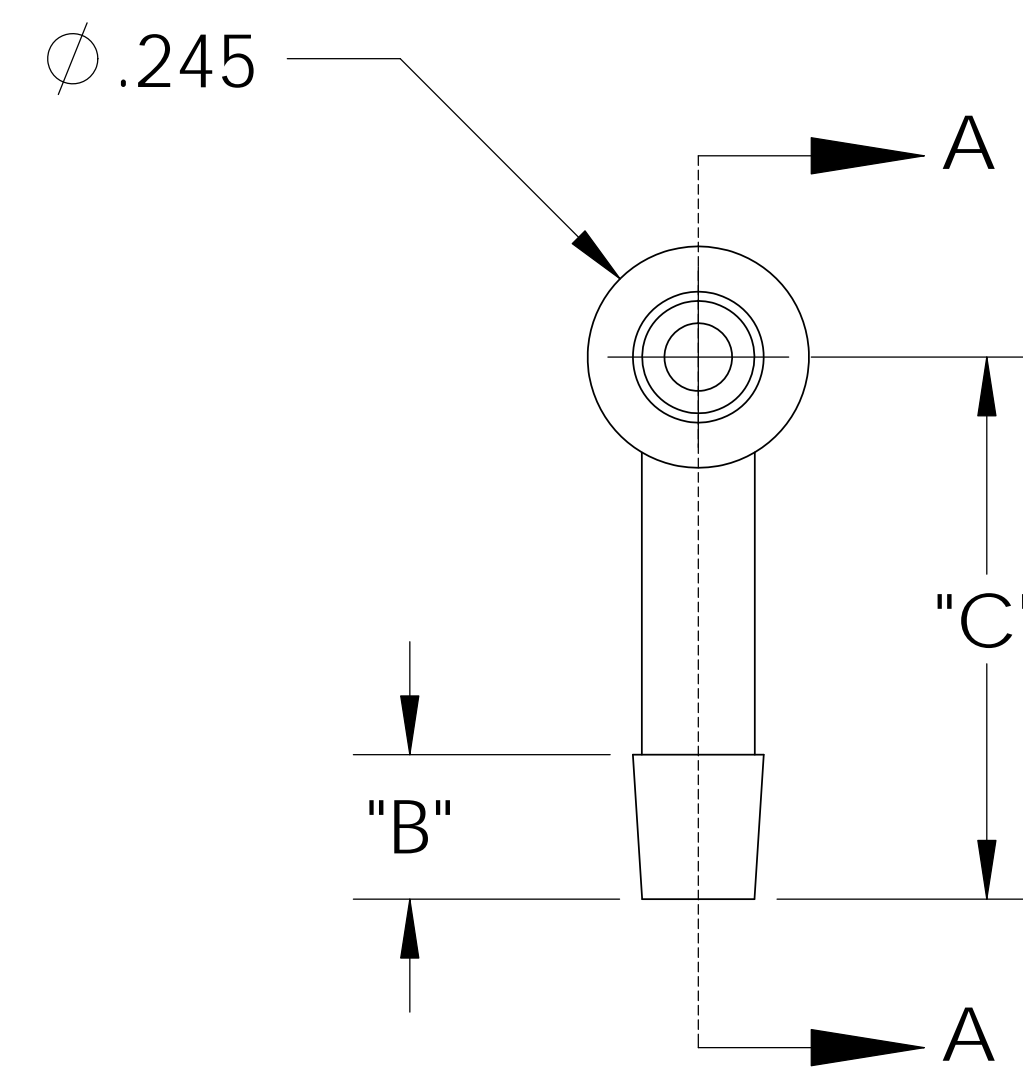

CATALOG NO.	DESCRIPTION	MATERIAL	DIM "A"	DIM "B"	DIM "C"	DIM "D"
TT9222/PP	1/8 X 1/8 X 1/8 PP	POLYPROPYLENE	.070	.155	.59	1.17
TT9222/P	1/8 X 1/8 X 1/8 P	POLYETHYLENE	.075	.155	.59	1.17
SHOWN TT9222/N	1/8 X 1/8 X 1/8 N	NYLON	.075	.160	.60	1.19

NOTES:
 1) POLYPROPYLENE HAS COLOR OPTIONS:
 BLACK = TT9222/PPB
 NATURAL = TT9222/PPN

PROPRIETARY AND CONFIDENTIAL
 THE INFORMATION CONTAINED IN THIS DRAWING IS THE SOLE PROPERTY OF THOGUS PRODUCTS COMPANY. ANY REPRODUCTION IN PART OR AS A WHOLE WITHOUT THE WRITTEN PERMISSION OF THOGUS PRODUCTS COMPANY IS PROHIBITED.

REV	WRO#	DESCRIPTION
D	95.00053	CONVERTED TO 3D FORMAT
HISTORY		

UNLESS OTHERWISE SPECIFIED:
 DIMENSIONS ARE IN INCHES
 TOLERANCES:
 ANGULAR: $\pm 0.5^\circ$
 X.X = ± 0.1
 X.XX = ± 0.05
 X.XXX = ± 0.015
 REMOVE ALL SHARP EDGES AND BURRS
 BLEND ALL RADII TO 0.01IN
 INTERPRET GEOMETRIC TOLERANCING PER: ANSI Y 14.5 1994
 MATERIAL:
 PP, P, N
 FINISH:
 NA
 THIRD ANGLE PROJECTION:

	NAME	DATE
DRAWN	KDJ	11/16/10
CHECKED	KDJ	11/16/10
ENG APPR.		XX/XX/XX
MFG APPR.		XX/XX/XX
Q.A.		XX/XX/XX

Thogus You think it, we can make it...
44012

TITLE:
1/8 BARB X 1/8 BARB X 1/8 BARB MINI TEE

SIZE B	DWG. NO. TT9222	REV D
SCALE: 2:1		MASS:
DO NOT SCALE DRAWING		SHEET 1 OF 1